

Installation Instructions

Stainless Steel Wall Guard - SSWG1

Data Sheet: Page 1 of 2 CD/PH January 2018

SSWG1

1. Cut the top retainer section to the length of the Stainless Steel Wall Guard cover minus 30mm at each end to prevent impingement with any end caps. Drill the retainer with $\varnothing 6$ mm holes along the central v-notch at a distance 20mm from each end and at regular intervals of between 600mm and 900mm depending upon the substrate. Similarly, for the bottom 'L' retainer section, cut it to the same length as the top retainer with the same size holes and spacings ensuring that the holes are all centred 12mm from the top edge of the long leg of the 'L'-shaped section.
2. Using a laser level, establish the line indicating where the top of the wall guard will sit against the wall (A).
3. From that line measure down 40mm and mark out the line on the wall (B). From that line, measure down a further 95mm and mark out another line (C).

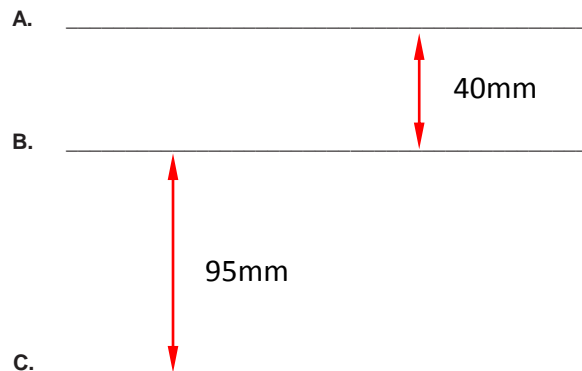

4. Position the top retainer against the wall aligning the hole centres with line B. Use the holes in the retainer as a template for marking the position of the holes in the wall. Similarly, for the bottom 'L'-shaped retainer section, use it as a template to mark the hole positions in the wall along line C.
5. Fix the top and bottom retainer sections to the wall using fixings compatible with the substrate (not supplied).
6. Fit the cover by hooking the top of the cover over the top of the top retainer section. Push the wall guard against the wall ensuring the bottom of the cover fits flush under the 'L' shaped bottom retainer (as shown in the drawing on page 2).

Note: Where multiple widths of wall guard are to be installed, the retainers and covers should be butt jointed ensuring that the joints in the retainer sections are staggered in relation to the joints in the cover sections.

7. Once the cover is in position, use the supplied no.8 pan head self-tappers to fasten through the holes in the base of the wall guard and into the bottom retainer section.

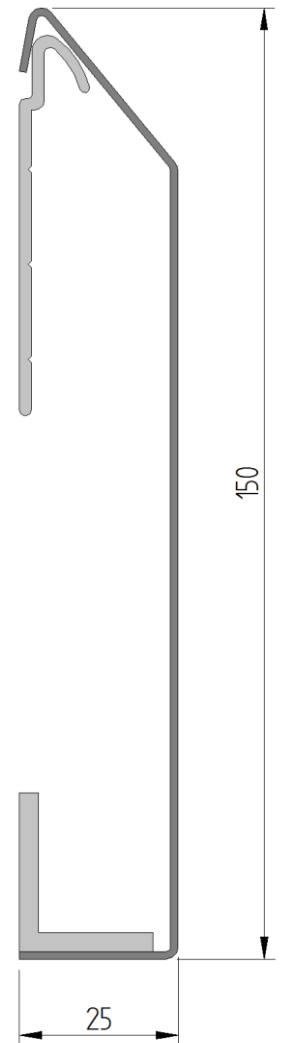

Installation Instructions

Stainless Steel Wall Guard - SSWG1

Data Sheet: Page 2 of 2 CD/PH January 2018

SSWGC1

